

HÖCHSTE PRÄZISION

Union Special®

LEWIS · COLUMBIA

NÄHMASCHINEN
FÜR DIE
INDUSTRIE

KLASSEN

41300 AA

41300 AB

41300 AC

41300 BA

41300 BB

41300 BC

41300 LB

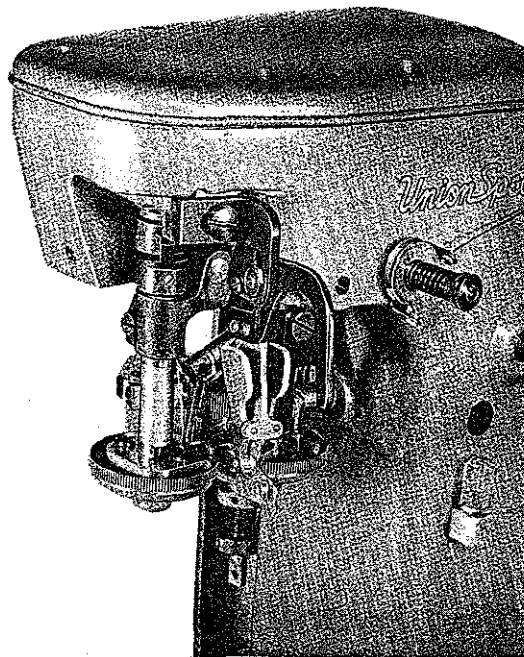

TELLERTRANSPORT-KETTENSTICH-
NÄHMASCHINEN

KATALOG
NR. 254

DA 1966

Union Special MASCHINENFABRIK G.M.
B.H. STUTT GART W SCHWABSTRASSE 33

Katalog Nr. 254

Catalog No. 254

Ersatzteile Katalog für die UNION SPECIAL Nähmaschine

Spare-Parts-Catalog for UNION SPECIAL-sewing-machines

Klasse 41300 AA

Classes AB

AC

BA

BB

BC

LB



Union Special[®] MASCHINENFABRIK G.M.
B. H.
7 STUTTGART-W Schwabstraße 33

Herausgegeben im Februar 1968

Issued February 1968

UNION SPECIAL MACHINE COMPANY
SPARE-PARTS CATALOG FOR UNION-SPECIAL-SEWING-MACHINES
CLASSES 41300 AA, AB, AC, BA, BB, BC, LB

MACHINE DESCRIPTION for 41300 AA, AB, AC.

One Needle Single Thread Chain Stitch, Double Feed Cup Machine, for seaming fully fashioned knitwear of wool, cotton and synthetics. Machine fitted with uncurler and chaining puller. Internal automatic lubrication.

Style 41300 AA for light weight material. Maximum sewing capacity set for 3 mm. Fabric guide G 41303 with guiding slot 1 mm deep.

Style 41300 AB same as 41300 AA, but with fabric guide G 41303 A with guiding slot 2 mm deep, for medium weight material.

Style 41300 AC same as 41300 AA and AB, but for heavy weight material maximum sewing capacity set for 4 mm. Fabric guide G 41303 B with guiding slot 3 mm deep.

The machines can easily be changed to double locked stitch machines (41300 BA, BB, BC) in replacing looper G 41308 AA by G 41308 BA.

MACHINE DESCRIPTION for 41300 BA, BB, BC, LB.

One Needle Double Locked Stitch, Double Feed Cup Machine, for seaming fully fashioned knitwear of wool, cotton and synthetics. Machine fitted with uncurler and chaining puller. Internal automatic lubrication.

Style 41300 BA for light weight material. Maximum sewing capacity set for 3 mm. Fabric guide G 41303 with guiding slot 1 mm deep.

Style 41300 BB same as 41300 BA, but with fabric guide G 41303 A with guiding slot 2 mm deep, for medium weight material.

Style 41300 BC same as 41300 BA and BB, but for heavy weight material maximum sewing capacity set for 4 mm. Fabric guide G 41303 B with guiding slot 3 mm deep.

The machines can easily be changed to single thread chain stitch machines (41300 AA, AB, AC) in replacing looper G 41308 BA by G 41308 AA.

Style 41300 LB same as 41300 BB for medium weight material, but with Fabric Uncurler Assembly 29450 S.

Seam specification:	Style 41300 AA, AB, AC 101/SSa-1 Style 41300 BA, BB, BC, LB 401/SSa-1
Length of stitch:	adjustable from 1.6 to 3.5 mm (also possible from 2.1 to 4.2 mm after readjusting, according to adjusting instructions)
Teeth cut:	1.1 mm = 140 teeth
Needle type:	8457 GS-048, available sizes: 036, 040, 044, 054
Maximum speed:	4000 R.P.M.
Hand wheel Ø:	57 mm
Pulley Ø:	80 mm with motor 2800 R.P.M.
Installation:	pedestal or sewing stand

UNION SPECIAL MASCHINENFABRIK GMBH
ERSATZTEILE-VERZEICHNIS FÜR DIE UNION SPECIAL-NÄHMASCHINE
KLASSE 41300 AA, AB, AC, BA, BB, BC, LB

MASCHINENBESCHREIBUNG für 41300 AA, AB, AC.

Einfachkettenstichnähmaschine mit zwei angetriebenen Transporttellern zum Zusammennähen von regulären (fully fashioned) Strick- und Wirkwaren. Mit Kantenentrollapparat und Kettelpuller. Automatische Sprühölung.

Klasse 41300 AA Für leichte Ware. Max.Stoffdurchgang auf 3 mm eingestellt. Stoffführung G 41303 mit 1 mm tiefer Führungsnute.

Klasse 41300 AB Wie 41300 AA aber mit Stoffführung G 41303 A mit 2 mm tiefer Führungsnute für mittlere Ware.

Klasse 41300 AC Wie 41300 AA und AB aber für starke Ware auf max.Stoffdurchgang von 4 mm eingestellt. Stoffführung G 41303 B mit 3 mm tiefer Führungsnute.

Durch Austausch des Greifers G 41308 AA gegen G 41308 BA können die Maschinen auf Doppelkettenstich (41300 BA, BB, BC) umgestellt werden.

MASCHINENBESCHREIBUNG für 41300 BA, BB, BC, LB.

Doppelkettenstichnähmaschine mit zwei angetriebenen Transporttellern zum Zusammennähen von regulären (fully fashioned) Strick- und Wirkwaren. Mit Kantenentrollapparat und Kettelpuller. Automatische Sprühölschmierung.

Klasse 41300 BA Für leichte Ware. Max.Stoffdurchgang auf 3 mm eingestellt. Stoffführung G 41303 mit 1 mm tiefer Führungsnute.

Klasse 41300 BB Wie 41300 BA aber mit Stoffführung G 41303 A mit 2 mm tiefer Führungsnute für mittlere Ware.

Klasse 41300 BC Wie 41300 BA und BB aber für starke Ware auf max.Stoffdurchgang von 4 mm eingestellt. Stoffführung G 41303 B mit 3 mm tiefer Führungsnute.

Durch Austausch des Greifers G 41308 BA gegen G 41308 AA können die Maschinen auf Einfachkettenstich (41300 AA, AB, AC) umgestellt werden.

Klasse 41300 LB Wie 41300 BB für mittlere Ware, aber mit Entrollapparat komplett 29450 S.

Nähart und Stichtype:	Klasse 41300 AA, AB, AC, 101/SSa-1 Klasse 41300 BA, BB, BC, LB 401/SSA-1
Stichlänge:	Einstellbar von 1,6 bis 3,5 mm (auch von 2,1 bis 4,2 mm nach Umstellung möglich)
Zahnteilung:	1,1 mm (140 Zähne auf Umfang)
Nadeltype:	8457 GS-048, lieferbar in den Stärken: 036, 040, 044, 054
Stichzahl:	4000 Stiche/Min.
Handrad ϕ :	57 mm
Keilriemenscheiben ϕ :	80 mm bei 2800 Motor-U/Min.
Aufstellung:	Auf Pedestal oder Stahlrohrtisch

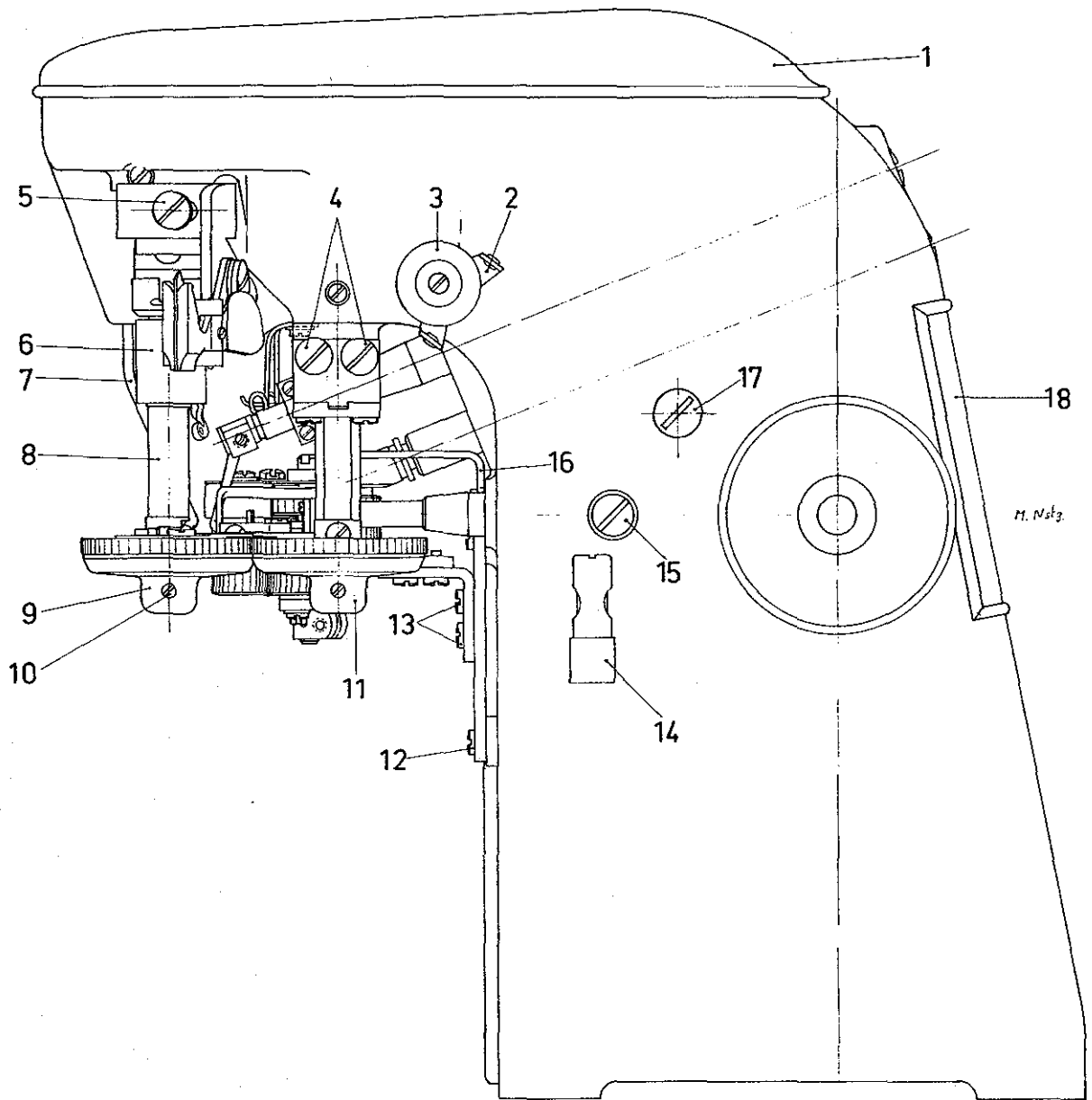

<u>Pos. Nr.</u>	<u>Teil Nr.</u>	<u>B e z e i c h n u n g</u>	<u>D e s c r i p t i o n</u>	<u>Anzahl</u>
<u>Ref. No.</u>	<u>Part No.</u>			<u>Amt. Req.</u>
1	41380 B	Oberer Deckel	Top Cover	1
2	51292 D	Fadenführung	Tension Eyelet	2
3	109	F'Sp'Scheibe	Tension Disc	1
4	22548	Schraube	Screw	2
5	318	Schraube	Screw	1
6	41361 N	Lager f. Tellerachse	Bearing f. Feed Cup	1
7	G 41325 AA	Nadelanschlag	Needle Guard	1
8	G 41364 AA	Führungslager	Bearing	1
9	41362 B	Transport-Teller	Feed Cup	1
10	88	Schraube	Screw	2
11	41362 B	Transport-Teller	Feed Cup	1
12	22805	Schraube	Screw	2
13	94	Schraube	Screw	2
14	41393	Ölsichtglas kompl.	Oil Sight Gauge Assembly	1
15	22733 B	Verschlusschraube	Plug Screw	1
16	G 41358 AA	N'Fadenführung	Needle Thread Eyelet	1
17	22539 E	Verschlusschraube	Plug Screw	4
18	41380 J	Hinterer Deckel	Rear Cover	1

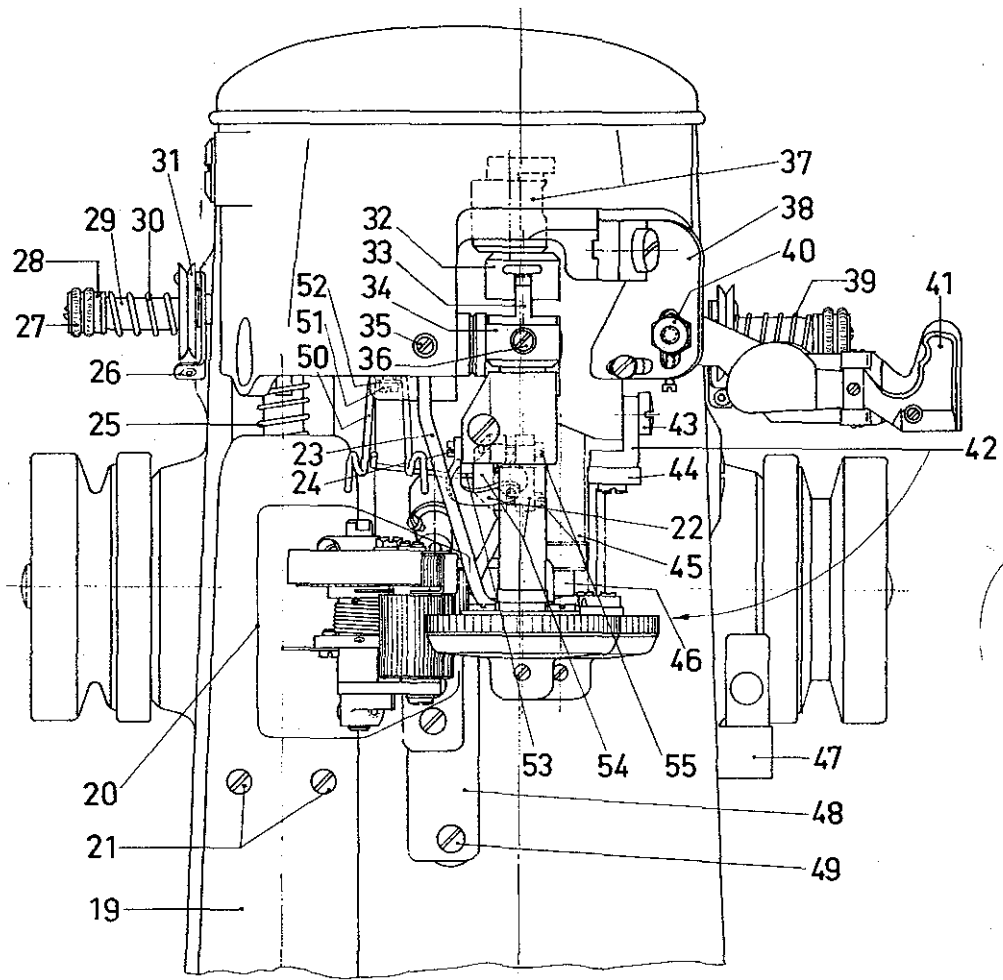

<u>Pos. Nr.</u>	<u>Teil Nr.</u>	<u>B e z e i c h n u n g</u>	<u>D e s c r i p t i o n</u>	<u>Anzahl</u>
<u>Ref. No.</u>	<u>Part No.</u>			<u>Amt. Req.</u>
19	41380 S	Abdeckplatte	Cover	1
20	G 41369 AA	Kettenpuller kompl. Besteht aus:	Chain Puller Assembly Analysis of No. G 41369 AA	1
		1-77 N Schraube	1-77 N Screw	
		2-G 41369 YN Pullerachse	2-G 41369 YN Shaft f. Puller Roll	
		1-G 41369 YS Pullerrolle vorne	1-G 41369 YS Puller Roll front	
		3-22704 Schraube	3-22704 Screw	
		3-41358 Scheibe	3-41358 Washer	
		1-G 41369 YL Diff. Pullerachse	1-G 41369 YL Differential Puller Shaft	
		1-G 41369 YR Pullerrad	1-G 41369 YR Gear	
		1-G 41369 YQ Pullerrolle hinten	1-G 41369 YQ Puller Roll rear	
		1-G 41369 YH Abweiser	1-G 41369 YH Chain Guard	
		3-22804 Schraube	3-22804 Screw	
		1-G 41369 YG Pullerradschutz	1-G 41369 YG Guard	
		1-166 Schraube	1-166 Screw	
		1-51235 G Scheibe	1-51235 G Washer	
		1-G 41369 YF Halter	1-G 41369 YF Mounting Bracket	
		2-22585 Schraube	2-22585 Screw	
		1-G 41369 YE Pullerträger	1-G 41369 YE Bracket	
		1-G 41369 YD Stellring	1-G 41369 YD Collar	
		1-87 U Schraube	1-87 U Screw	
		1-1741 B Messer	1-1741 B Chain Cutting Knife	
		1-G 41369 YC Pullerfeder	1-G 41369 YC Spring	
		1-G 41369 YP Zwischenrad	1-G 41369 YP Intermediate Gear	
		1-G 41369 YA Zwischenradachse	1-G 41369 YA Shaft for Intermediate Gear	
21	22849	Schraube	Screw	2
22	G 41376 A	Gr. F' Führung	Looper Thread Eyelet	1
23	G 41325 AA	Nadelanschlag	Needle Guard	1
24	77 L	Schraube	Screw	1
25	41375 N	Drückerfußfeder	Presser Spring	1
26	51292 D	Fadenführung	Tension Eyelet	2
27	108	F'Sp' Mutter	Tension Nut	2
28	107	F'Sp' Hülse	Tension Spring Ferrule	2
29	G 41392 Y	F'Sp' Bolzen	Tension Post	2
30	51292 F-2	F'Sp' Feder	Tension Spring	1
31	109	F'Sp' Scheibe	Tension Disc	4
32	41363 A	Trspt.-Teller-Achse	Feed Cup Shaft	1
33	G 41363 Y	Kreuzstück	Floating Connector	1
34	41363	Trspt.-Teller-Achse	Feed Cup Shaft	1
35	22560 B	Schraube	Screw	1
36	22516 A	Schraube	Screw	1
37	G 41360 Y	Exzenter Buchse	Eccentric	1
38	G 29478 BV	Apparate-Halter kompl. Besteht aus:	Uncurler Mounting Bracket Assembly Analysis of No. G 29478 BV	1
		1-G 41370 AT Halter	1-G 41370 AT Mounting Bracket	
		1-99310 Schraube	1-99310 Screw	
		1-99309 Stellmutter	1-99309 Nut	
		1-14077 Mutter	1-14077 Nut	
		1-43232 R Federscheibe	1-43232 R Spring Washer	
		1-22704 Schraube	1-22704 Screw	
		1-22738 D Schraube	1-22738 D Screw	
		1-G 41370 AD Zwischenstück	1-G 41370 AD Uncurler Operating Lever	
39	51292 F-8	F'Sp' Feder	Tension Spring	1
40	14077	Mutter	Nut	1
41	G 29450 RD	Entrollapparat kompl. für Klasse 41300 AA, AB, AC für Klasse 41300 BA, BB, BC	Uncurler Assembly for Styles 41300 AA, AB, AC for Styles 41300 BA, BB, BC	1
	29450 S	Entrollapparat kompl. für Klasse 41300 LB	Uncurler Assembly for Style 41300 LB	1
42	41366 N	Haltewinkel	Fabric Support Bracket	1
43	22548	Schraube	Screw	2
44	41366 P	Haltewinkel	Fabric Support Intermediate Bracket	1
45	41364 J	Büchse	Bearing Lower	1
46	41363 J	Achse	Feed Cup Shaft	1
47	41393	Ölsichtglas kompl.	Oil Sight Gauge Assembly	1
48	G 41367 Z	Haltewinkel	Puller Mounting Bracket	1
49	94	Schraube	Screw	2
50	G 41376 AA	Doppelfadenführung	Thread Eyelet	1
51	22585	Schraube	Screw	1
52	80040-1	Scheibe	Washer	1
53	G 41376 AB-2	Fadenabzugshaken	Pull-off Wire	1
54	G 41376 AB-1	Halter für Fadenabzugshaken	Holder for Pull-off-Wire	1
55	92125 A	Schraube	Screw	2

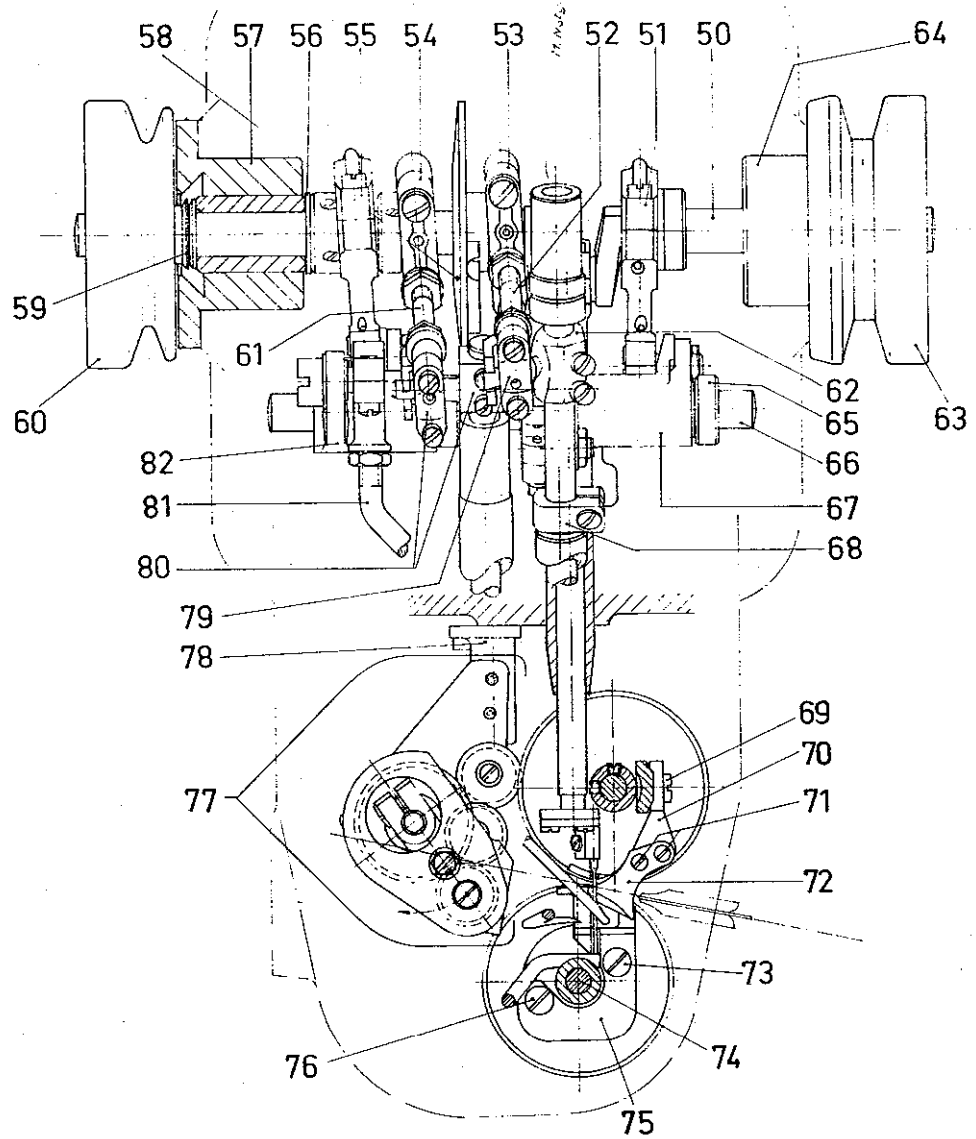

<u>Pos. Nr.</u> <u>Ref. No.</u>	<u>Teil Nr.</u> <u>Part No.</u>	<u>B e z e i c h n u n g</u>	<u>D e s c r i p t i o n</u>	<u>Anzahl</u> <u>Amt. Req.</u>
50	G 29476 R	Kurbelwelle kompl.	Crankshaft Assembly	1
51	G 29126 X	Stecker-Hub-Verbindungslager kpl.	Spreader Eccentric Assembly	1
52	41331 G	Verbindungsstange	Looper Eccentric Connecting Rod	1
53	29126 AN	Greiferexzenter kompl.	Looper Eccentric Assembly	1
54	G 29126 Y	Stecker-Schwingeexzenter kompl.	Spreader Motion Eccentric Assembly	1
55	G 29126 AL	Transportexzenter kompl.	Feed Eccentric Assembly	1
56	35746 A	Unterlegscheibe	Washer	1
57	41390 A	Lager m. Büchse	Crankshaft Bearing	1
58	41381 E	Ölverteilerscheibe kompl.	Oil Distributing Disc	1
59	660-204	Ölabstreifring	Oil Seal Ring	2
60	41321 C	Handrad links	Round Belt Pulley	1
61	41037 A	Verbindungsstange	Connecting Rod	1
62	41332 G	Gelenk	Link	1
63	41321 B	Handrad rechts	Belt Pulley	1
64	41390 C	Lager m. Büchse	Crankshaft Bearing	1
65	39147 D	Stellring	Collar	3
66	G 41335 A	Greiferhebelachse	Looper Rocker Shaft	1
67	G 41332 Y	Doppelhebel	Lever	1
68	41039 A	Verbindungsring	Collar	1
69	94	Schraube	Screw	1
70	G 41366 AA	Stoffführungshalter	Bracket for Fabric Guide	1
71	22798 A	Schraube	Screw	2
72	G 41303	Stoffführung f. Klasse 41300 AA, BA	Fabric Guide for Styles 41300 AA, BA	1
	G 41303 A	Stoffführung f. Kl. 41300 AB, BB, LB	Fabric Guide for Styles 41300 AB, BB, LB	1
	G 41303 B	Stoffführung f. Klasse 41300 AC, BC	Fabric Guide for Styles 41300 AC, BC	1
73	22585 A	Schraube	Screw	2
74	41361	Achse	Shaft	1
75	G 41324 AA	Stichplatte	Throat Plate	1
76	22585 A	Schraube	Screw	2
77	G 41369 AA	Kettenpuller kompl.	Chain Puller Assembly	1
78	41367 Z	Halte winkel f. Kettenpuller	Puller Attaching Bracket	1
79	41332 F	Greiferachse-Verbindungslager	Looper Bar Ball Joint Assembly	1
80	G 29126 Z	Doppelkugelkopf kompl.	Double Ball Joint Assembly	1
81	29478 BM	Verbindungsstange kompl.	Connecting Rod Assembly	1
82	41355 A	Stichstell-Segmenthebel	Stitch Regulating Segment Lever	1

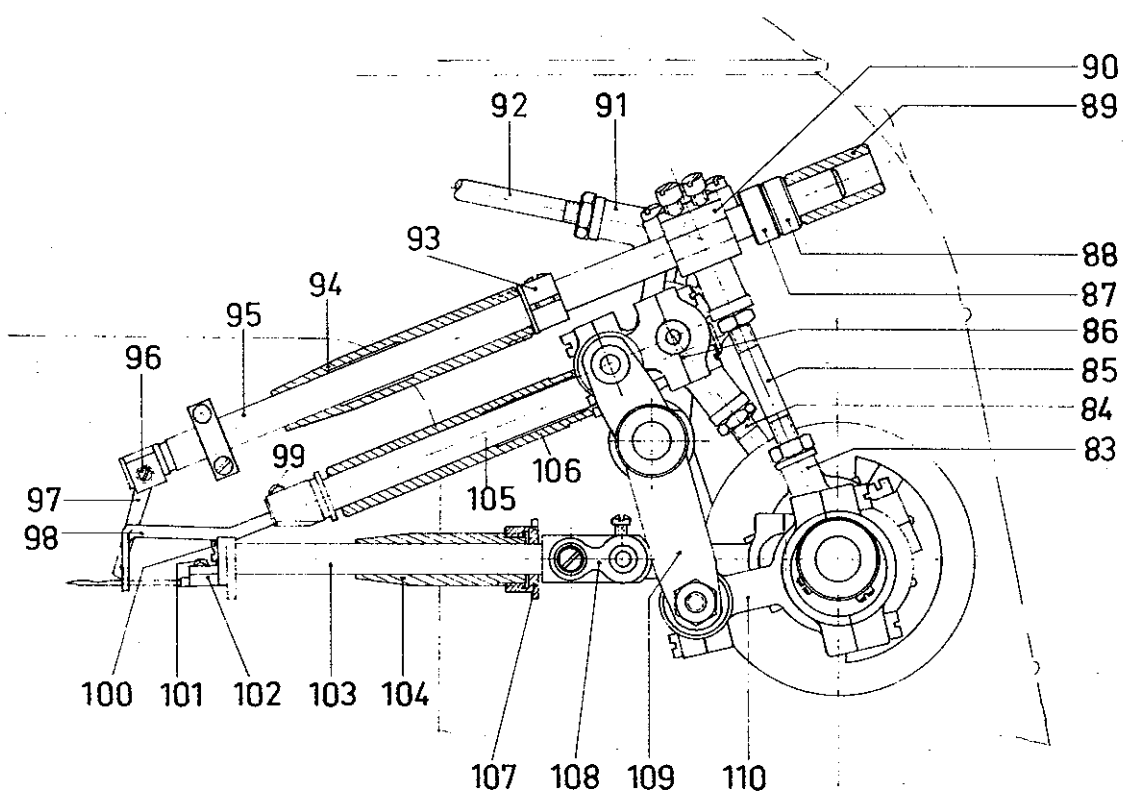

<u>Pos. Nr.</u>	<u>Teil Nr.</u>	<u>B e z e i c h n u n g</u>	<u>D e s c r i p t i o n</u>	<u>Anzahl</u>
<u>Ref. No.</u>	<u>Part No.</u>			<u>Amt. Req.</u>
83	29126 AN	Greiferexzenter kompl.	Looper Eccentric Assembly	1
84	41037 A	Verbindungsstange	Connecting Rod	1
85	41331 G	Verbindungsstange	Connecting Rod	1
86	G 29126 Z	Doppelkugelkopf kompl.	Double Ball Joint Assembly	1
87	12865	Anschlag-Stellring	Thrust Collar	1
88	G 41364 Y	Distanzring	Washer	1
89	41332 B	Büchse hinten f.Gr.-Achse	Bushing f.Looper Bar rear	1
90	41332 F	Verbindungslager kompl.	Looper Bar Ball Joint Assembly	1
91	41357 J	Kugelgelenk	Ball Joint	1
92	29478 BM	Verbindungsstange kompl.	Rod Assembly	1
93	41039 A	Verbindungsring	Collar	1
94	41332 A	Büchse vorn f. Gr.-Achse	Bushing f.Looper Bar, front	1
95	41332 T	Greiferachse	Looper Bar, front	1
96	22565	Schraube	Screw	1
97	G 41308 AA	Greifer f.Klasse 41300 AA,AB,AC	Looper for Styles 41300 AA,AB,AC	1
	G 41308 BA	Greifer f.Klasse 41300 BA,BB,BC LB	Looper for Styles 41300 BA,BB,BC LB	1
98	G 41311 AA	Stecher	Spreader	1
99	33174 B	Schraube	Screw	1
100	605 A	Schraube	Screw	1
101	22798 A	Schraube	Screw	1
102	G 41318 Y	Nadelhalter	Needle Holder	1
103	G 41317 Y	Nadelstange	Needle Bar	1
104	41350 U	Nadelst.-Büchse	Bushing for Needle Bar	1
105	G 41342	Stecherachse	Spreader Bar	1
106	G 41342 Y	Stecherbüchse	Spreader Bar Bushing	1
107	41350 V	Ölabstreifplatte	Oil Seal Cap	1
108	41350	Verbindungslager	Needle Bar Link Assembly	1
109	G 41332 Y	Doppelhebel	Lever	1
110	G 29126 X	Stecher-Hub-Verbindungslager kompl.	Spreader Eccentric Assembly	1

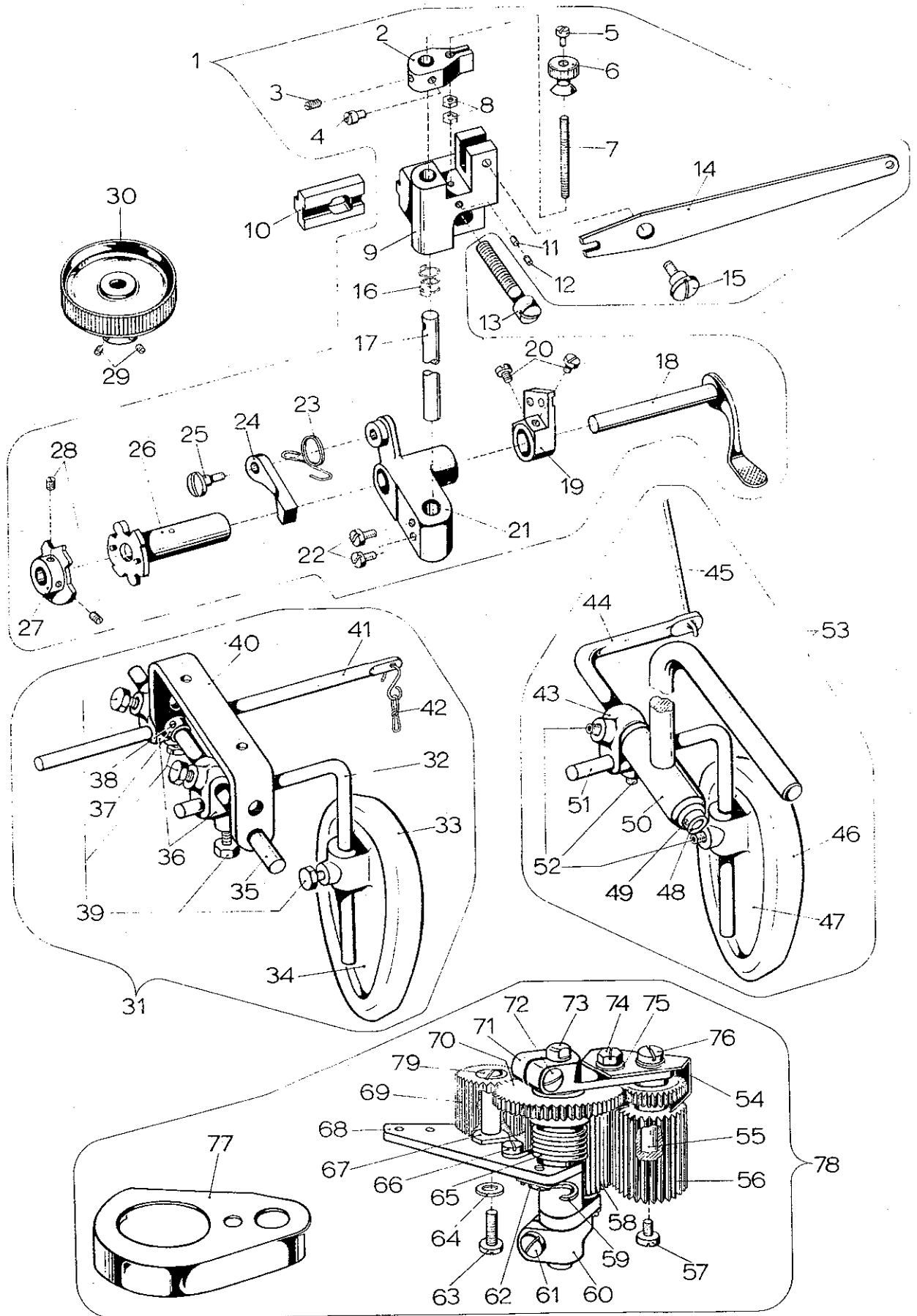

<u>Pos. Nr.</u>	<u>Teil Nr.</u>	<u>Bezeichnung</u>	<u>Description</u>	<u>Anzahl</u>
<u>Ref. No.</u>	<u>Part No.</u>			<u>Amt. Req.</u>
1	29478 BV	Entrollapparat Halter kompl.	Uncurler mounting Assembly	1
2	41370 BD	Stellring mit Führung	Sliding Bracket Guide	1
3	22724	Schraube	Screw	1
4	22845 G	Schraube	Screw	1
5	90	Schraube	Screw	1
6	41370 AF	Rändelmutter	Adjusting Stud Nut	1
7	41370 AX	Einstellbolzen	Adjusting Stud	1
8	41071 G	Mutter	Nut	2
9	41370 AT	Halter	Mounting Bracket	1
10	G 41370 Y	Zwischenstück	Bracket	1
11	41370 AY	Druckstück	Adjusting Stud Locking Insert	1
12	22743	Schraube	Screw	1
13	22806	Schraube	Screw	1
14	41370 AD	Hebel f. Aufrollapparat- Verstellung	Fabric Uncurler Support Sliding Arm Operating Lever	1
15	22557	Schraube	Screw	1
16	41370 AW	Feder	Spring	1
17	41370 AV	Achse f. Halter	Mounting Bracket Shaft	1
18	41370 H	Rasthebel	Fabric Uncurler Unlocking Lever	1
19	41370 A	Halter f. Aufrollapparat	Fabric Uncurler Support Bracket	1
20	22830	Schraube	Screw	2
21	41370 BC	Schwenkarm	Sliding Bracket	1
22	94	Schraube	Screw	2
23	41370 V	Feder	Spring	1
24	41370 U	Raste	Fabric Uncurler Ratchet Pawl	1
25	22504 A	Schraube	Screw	1
26	41370 P	Sperrad hinten	Fabric Uncurler Ratchet rear	1
27	41370 N	Sperrad vorn	Fabric Uncurler Ratchet front	1
28	89	Schraube	Screw	2
29	88	Schraube	Screw	2
30	G 41362 Y	Transportteller	Feed Cup	1
31	79084 D	Kniehebel kompl.	Knee Lever compl.	1
32	G 21667 D	Hebelstange	Plate Rod	1
33	21677 E	Gummipolster	Pad	1
34	21677 D	Kniedruckscheibe	Knee Press Plate	1
35	21679	Querachse	Knee Press Bracket Shaft	1
36	21665	Kreuzstück	Chain Rod and Plate Connection	2
37	9271	Stellring	Collar	1
38	98	Schraube	Screw	1
39	95052	Schraube	Screw	5
40	21662	Winkellager	Knee Press Bracket	1
41	21661	Achse	Shaft	1
42	421 C-10	Kette	Knee Press Chain	1
43	21665	Kreuzstück	Chain Rod and Plate Connection	1
44	G 21661 H	Zughebel	Lever	1
45	G 1450 N-2	Zugstange	Connecting Rod	1
46	21677 E	Gummipolster	Pad	1
47	61677 D	Kniedruckscheibe	Knee Press Plate	1
48	9271	Stellring	Collar	1
49	22580	Schraube	Screw	2
50	G 21662 H	Lagerhalter	Knee Press Bracket	1
51	G 21667 D	Hebelstange	Lever	1
52	95510	Gewindestift	Screw	3
53	79084 G	Kniehebel kompl.	Knee Lever compl.	1
54	G 41369 YH	Abweiser	Cloth Deflector	1
55	G 41369 YN	Pullerachse	Puller Shaft	1
56	G 41369 YS	Pullerrolle vorn	Puller Roll front	1
57	22704	Schraube	Screw	1
58	G 41369 YQ	Pullerrolle hinten	Puller Roll rear	1
59	1741 B	Messer	Chain Cutting Knife	1
60	G 41369 YD	Stellring	Collar	1
61	22585	Schraube	Screw	1
62	87 U	Schraube	Screw	1
63	22804	Schraube	Screw	1
64	41358	Scheibe	Washer	1
65	G 41369 YC	Pullerfeder	Puller Spring	1
66	77 N	Schraube	Screw	1
67	G 41369 YL	Pullerachse	Puller Shaft	1
68	G 41369 YE	Pullerträger	Puller Bracket	1
69	G 41369 YR	Pullerrad	Puller Gear	1
70	G 41369 YP	Zwischenrad	Intermittent Gear	1
71	G 41369 YF	Halter f. vord. Pullerrolle	Bracket for Puller Rolle front	1
72	22585	Schraube	Screw	1
73	G 41369 YA	Zwischenradachse	Shaft for Intermittent Gear	1
74	166	Schraube	Screw	1
75	51235 G	Scheibe	Washer	1
76	22804	Schraube	Screw	1
77	G 41369 YG	Pullerradschutz	Puller Guard	1
78	G 41369 AA	Puller kompl.	Puller compl.	1
79	22704	Achse	Shaft	1

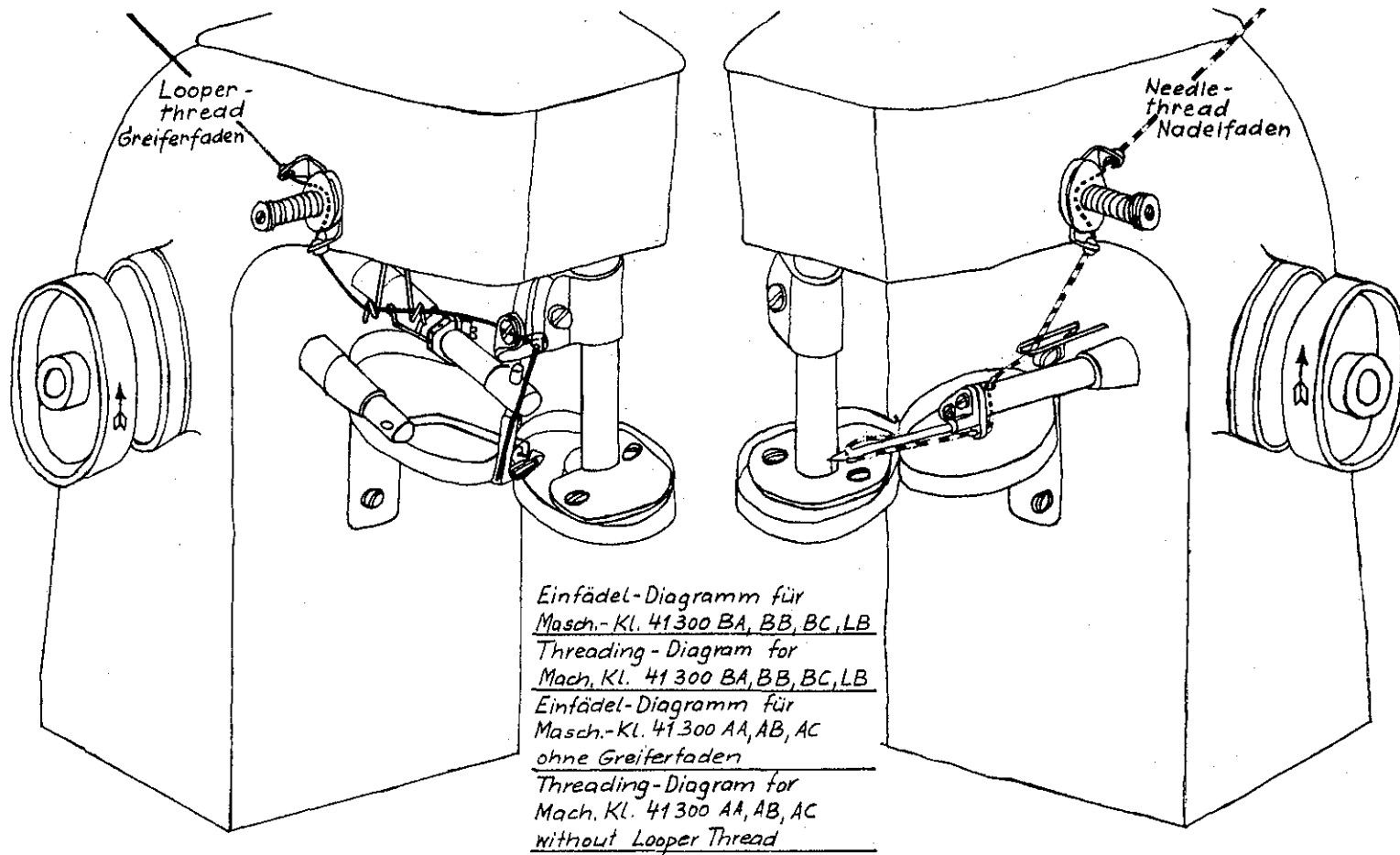



Union Special[®]
INDUSTRIAL SEWING MACHINES

UNION SPECIAL maintains sales and service facilities throughout the world. These offices will aid you in the selection of the right sewing equipment for your particular operation. Union Special representatives and service men are factory trained and are able to serve your needs promptly and efficiently. Whatever your location, there is a Union Special Representative to serve you. Check with him today.

ATLANTA, GA.

BOSTON, MASS.

CHICAGO, ILL.

DALLAS, TEXAS

LOS ANGELES, CAL.

NEW YORK, N. Y.

PHILADELPHIA, PA.

MONTREAL, CANADA

TORONTO, CANADA

BRUSSELS, BELGIUM

LEICESTER, ENGLAND

LONDON, ENGLAND

PARIS, FRANCE

STUTT GART, GERMANY

Representatives and distributors in all important industrial cities throughout the world.

UNION SPECIAL CORPORATION
400 N. FRANKLIN ST., CHICAGO, ILL. 60610